

INSTRUCTION MANUAL

Indirect control pushbutton switch (contact switch)

Model: SBI



- Ask users to read through this manual before using this product.

 **SHINKOH ELECTRIC CO.,LTD.**

Introduction



Thank you for purchasing the SHINKOH pushbutton switch.

This instruction manual provides the information necessary for installation and wiring of the pushbutton switch, and for the crane/hoist operations. Description of this instruction manual is intended for qualified personnel and those with expertise. Before installation and wiring of the pushbutton switch and operation of the crane/hoist, be sure to read this manual carefully to understand the contents. Operators should always keep this manual handy so that it can be read whenever required. For the contents particularly required in terms of safety, refer to JCA Standards, JCAS1001-02: “Safety Guideline for Cranes Controlled with Pendant Switch”(established in April 2002).

Safety Precautions

Most of the accidents related to crane/hoist operations controlled with pendant switches are caused by negligence in observing fundamental safety instructions and predicting hazards. Before installation, operation, control, maintenance and inspection, be sure to read this instruction manual thoroughly to ensure proper use of the equipment. Before using the equipment, be sure to have a thorough knowledge of the equipment, safety information and all other instructions.

In this manual, instructions are classified into the two categories: “DANGER” and “CAUTION”.

 [DANGER]	[DANGER] indicates potentially hazardous conditions that will result in death or serious injury if the equipment is improperly handled.
 [CAUTION]	[CAUTION] indicates potentially hazardous conditions that may result in medium/slight injury or property damage if the equipment is improperly handled.

Even the conditions categorized as [CAUTION] may result in serious hazard depending on situations. All instructions provide important information. Be sure to observe them.

Example of the symbols used in this manual





△ indicates hazards to which you must pay attention. Specific instructions are given in the symbol.

○ indicates prohibited actions. Specific actions to be prohibited are given in the symbol or nearby.



● indicates the actions and instructions that you are compelled to conduct and observe. Specific instructions are given in the symbol or nearby.

* After reading this manual, be sure to keep it in place for future reference.



1. Precautions for overall handling of the equipment



 [DANGER]	
- People who are not familiarized with the contents of the instruction manual must not operate the equipment. The qualification is needed according to the usage.	
- Be sure to conduct preoperational inspection and voluntary periodic inspection.	

2. Precautions for wiring and installation



 [DANGER]	
- Any person other than qualified personnel or those with expertise must not conduct wiring or installation of the equipment. - Do not install the equipment in a place other than the specified environment, such as in a puddle or submersible environment.	



3. Precautions for operation and control

 [DANGER]	
- Check operations of the pushbuttons before use. If they do not smoothly work, do not operate it. - If the crane/hoist moves in a different direction regardless of the control via the pushbutton switch, stop operation immediately. - If the pushbutton case has a cut, crack or other damage, do not operate it.	

 [CAUTION]	
- Do not use the equipment under conditions beyond the specified electrical ratings. - Do not perform plucking (abrupt return) or excessive inching. - Do not allow the pushbutton switch cable to be caught in other objects. Do not apply strong tension to the cable. - Do not remove the “WARNING” and “CAUTION” plates or labels attached to the body. Do not leave the plates or labels illegible.	
- Clean the area around the pushbutton switch to keep it free from dust or sand.	

4. Precautions for maintenance, inspection and modification

 [DANGER]	
- Do not modify this product or accessories. - Do not use any parts other than SHINKO genuine parts.	
- Before maintenance, inspection or repair, be sure to turn OFF the power switch. - Maintenance, inspection and repair must be conducted by authorized personnel with expertise. - Maintenance, inspection and repair must be conducted with a crane/hoist under no load. - If any defect is found in maintenance or inspection, do not leave it, and repair it immediately.	

 [CAUTION]	
- During maintenance, inspection and repair work, be sure to provide signs indicating that the machine is “UNDER INSPECTION”, or “DO NOT TURN ON POWER”.	

Contents

Introduction	-----	P.1
Safety Precautions	-----	P.1
Contents	-----	P.3
[1] Part names / Tightening torque / Identification plates		
1-1 Example: Model SBI-8-WZ	-----	P.4
1-2 Details of the identification plates	-----	P.5
[2] Checking your pushbutton switch		
2-1 Outline of specifications	-----	P.5
2-2 Checking your product	-----	P.5
[3] Description of the main components and auxiliary components		
3-1 Contact configuration of the switch unit	-----	P.5
3-2 Cable armour and auxiliary cable armour	-----	P.6
3-3 Button hood	-----	P.8
3-4 Blank plug	-----	P.8
3-5 Top cover	-----	P.9
3-6 Protector	-----	P.9
3-7 S-shaped ring	-----	P.9
[4] Wiring, assembly and installation of the pushbutton switch		
4-1 Wiring and assembly procedures	-----	P.11
4-2 Assembly precautions	-----	P.11
[5] Precautions for crane/hoist operations		
5-1 Precautions for operation and control	-----	P.13
5-2 Emergency procedure	-----	P.13
[6] Inspection standards		
6-1 Preoperational inspection	-----	P.14
6-2 Voluntary periodic inspections	-----	P.14
[7] Maintenance		
7-1 Replacement of the switch unit	-----	P.15
7-2 Replacement of the button hood	-----	P.15
7-3 Replacement of the pilot lamp, buzzer switch and control switch	-----	P.16
[8] Warranty		
8-1 Scope and period of warranty	-----	P.18
8-2 Exemptions from warranty	-----	P.18

[1] Part names / Tightening torque / Identification plates

1-1 Example: Model SBI-8-WZ

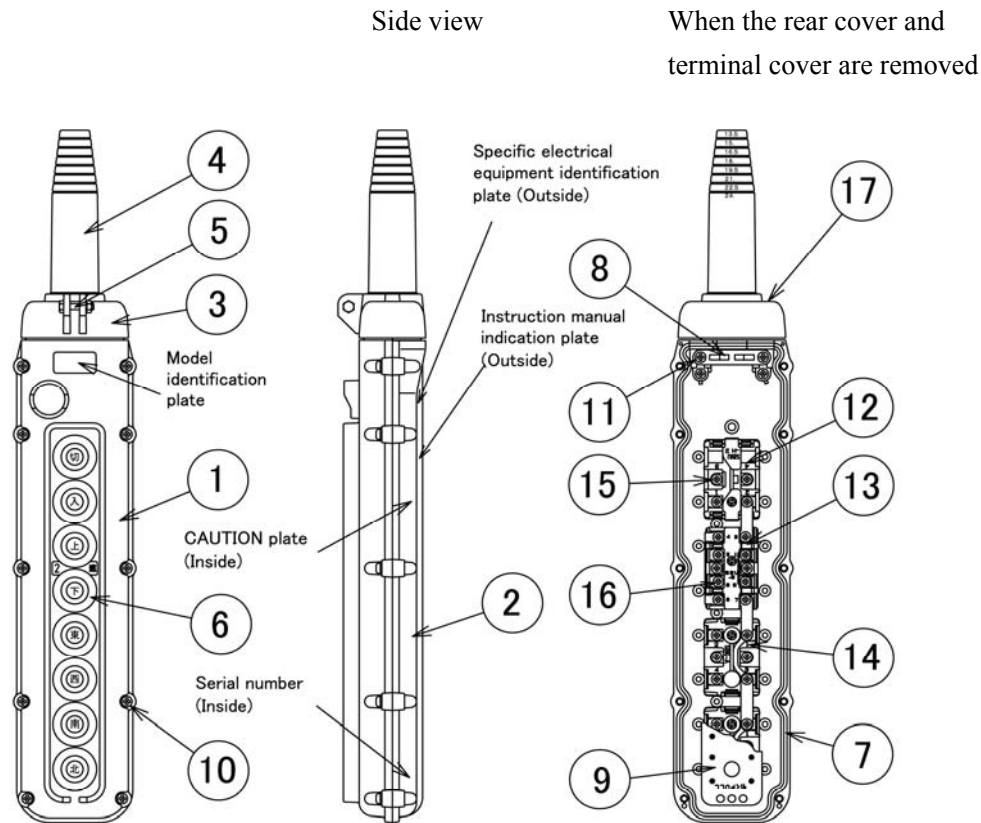

Parts list

No.	Description	Tightening torque N.m (kgf·cm)	Remarks
1	Case		
2	Rear cover		M4 nut welded
3	Top cover		
4	Cable armour		
5	Hexagonal bolt		Wire mounting bolt with M4 nut
6	Button hood		with seal ring and button mark plate
7	String packing		
8	Cable holder		
9	Terminal cover		Type: TC-8
10	Screw M4 x 17.5	1.0 - 1.5 (10-15)	Case tightening screw
11	Screw M4 x 20.5		Cable holder screw
12	Switch unit		Model SBIU-H2
13	Switch unit		Model SBU-S
14	Switch unit		Model SBIU-A
15	Forming screw 4mm x 18	1.0 - 1.4 (10-14)	
16	Terminal screw M4 x 6	1.2 - 1.4 (12-14)	
17	Screw M5 x 20	2.0 - 2.6 (20-25)	Top cover tightening screw

· Tightening torque

When tightening each part, follow the tightening torque listed in the parts list on page 4.

1-2 Details of the identification plates

Model identification plate

* Attached to the front of the case



Specific electrical appliances identification plate

* Attached to the outside of the rear cover



For electromagnetic switching operation,
Rainproof type

CAUTION plate

* Printed on the inside of the rear cover

ご 注 意

1. 端子部の配線には必ず丸形圧着端子をご使用下さい。
2. 屋外ご使用の場合補助防水ケーブルアーマーをご使用下さい。
3. ケース各部のネジは確実に締付けて下さい。

CAUTION

1. For terminal connections, be sure to use round crimp terminals.
2. To use the pushbutton switch outdoors, mount the auxiliary cable armour.
3. Make sure that the screws in the case are securely tightened.

Instruction manual indication plate

* Attached to the outside of the rear cover

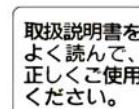

To ensure proper use, read the instruction manual thoroughly.

[2] Checking your pushbutton switch

2-1 Outline of specifications

- Conformity to the requirements for specific electrical appliances
Pushbutton switch for operation circuit (indirect control), Rainproof type
Rating: 3A, 250 VAC (for electromagnetic switching operation)
- Type SBI series, made of polycarbonate resin
- Installation environment -5 to 40°C (no condensation, no freezing)
*A part of part exchange is necessary when using it at 0°C or less
- Number of buttons 2 to 12

2-2 Checking your product

Confirm that the delivered pushbutton switch is as per your order.

- Contact configuration of the switch unit
- Accessories: Instruction manual
Round crimp terminals
(Quantity: One for input, plus as many as the number of output terminals)
- Check if the product is not damaged during transportation.
- For inquiry on the pushbutton switch, inform us of the serial number printed on the inside of the rear cover.

[3] Description of the main components and auxiliary components

3-1 Contact configuration of the switch unit

Switch unit	Contact configuration		Switching mechanism	Remarks / Mounting screw
SBIU-A	1a	1a	Momentary type	4mm x 18 2 forming screws
SBU-B	1a	1b		
SBU-AB	1a+1b	1a+1b		
SBIU-H2	1a	—	Holding type	
SBIU-H3	1a	1b		

Switch unit	Contact configuration		Switching mechanism	Remarks / Mounting screw
SBU-S	1a+1a	1a+1a	Momentary type, 2 speed	4mmx18 2 forming screws
SBIU-T	1a+1a+1a	1a+1a+1a	Momentary type, 3 speed	4mm x10 4 forming screws
SBIU-KS2	1a		Holding-type setting knob	4mm x 10 2 forming screws
SBIU-KS4	1a+1a			
SBIU-L2	1a			
SBIU-L3	1a+1a		Push-lock, turn-reset type	
SBIU-L3B	1a+1a			
SBIU-EL1	1a+1b		Momentary type	
SBIU-EH1	1a+1b			
SBIU-A1	1a			
SBIU-AB1	1a+1b			
SBPU-BzS	1a			M14 nut (Mounting hole diameter: 13.5)
SBU-H1	1b		Push-pull type	M16 nut (Mounting hole diameter: 16.2)
PLH-220	Light source: Neon		220V AC	M14 nut (Mounting hole diameter: 13.5) Color: Red, Green and White
PLH-110			110V AC	
PLH-24F	Light source: Filament		24V AC/DC	

NOTE:

1. The emergency stop unit is protruding from the rib more than other units.

Therefore, handling the emergency stop unit carelessly causes a failure of the unit.



To reduce impact onto the unit, it is recommended that the unit should be mounted at the uppermost position (on the cable side).

2. The SBP series (SBPU-S etc.) cannot be mounted.

3-2 Cable armour and auxiliary cable armour

(1) Cable armour

- The cable armour is used to ensure sealing effect of the cable insertion part, and to protect the cable.

 [DANGER]	<p>- When selecting the cable armour, make sure that the cable armour tip inner diameter is smaller than the cable outer diameter.</p> <p>* If the cable armour tip inner diameter is larger than the cable outer diameter, water or dust may enter the case.</p> <p>This will result in a switch failure, or cause the crane/hoist to run out of control.</p>	
---	---	---

- Shape and inner diameter of the cable armour tip

(∇ indicates the cutting position.)

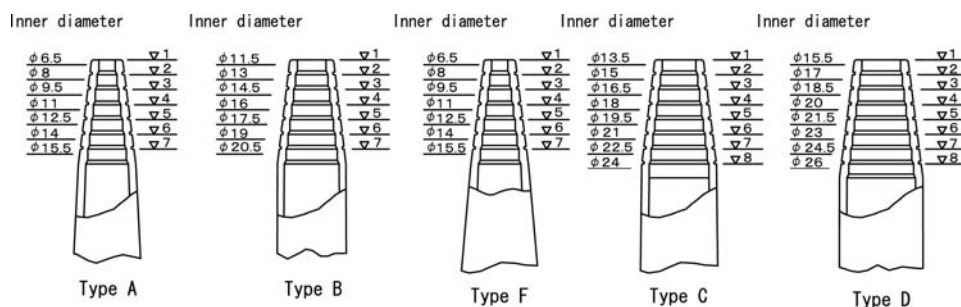

Applicable push-button switch model	Type	Inner diameter (mm)							
		▽1	▽2	▽3	▽4	▽5	▽6	▽7	▽8
SBI-2-W□ SBI-3-W□ SBI-4-W□	A(*)	6.5	8	9.5	11	12.5	14	15.5	
SBI-5-W□ SBI-6-W□	B(*)	11.5	13	14.5	16	17.5	19	20.5	
SBI-7-W□ SBI-8-W□ SBI-10-W□	F(**) C(**)	6.5 13.5	8 15	9.5 16.5	11 18	12.5 19.5	14 21	15.5 22.5	24
SBI-12-W□	D	15.5	17	18.5	20	21.5	23	24.5	26

* Type A and type B are compatible with each other. To use a pushbutton switch other than the above, specify the model when placing an order.

** Type C and type F are compatible with each other. It is shipped by type C when there is no support.

- To ensure stable sealing effect of the cable armour, cut the tip of the cable armour at the position where the cable armour inner diameter becomes at least 1.5 mm smaller than the outer diameter of the connection cable. If such a cutting position cannot be selected, we recommend you to use the auxiliary cable armour.

- Example of the cable armour cutting position and inner diameter selection

* Pushbutton switch: Model SBI-2-W

* Outer diameter of the cable used: 11 mm

* $11 - 1.5 = 9.5$ mm (or less)

* Cut the cable armour at the ▽3 position of Type A. (Inner diameter : 9.5 mm)

(2) Auxiliary cable armour

Auxiliary cable armour Unit: mm

Model	Applicable cable outer diameter
HAI-7	8 - 13
HAI-12	13 - 17
HAI-16	17 - 27.5

- The auxiliary cable armour is a component for reinforcing the waterproof effect between the cable and the cable armour.

- It is recommended that the auxiliary cable armour should be mounted in the following conditions:

- When the pushbutton switch is installed outdoors, or in an equivalent place
- When you cannot select the cable armour whose inner diameter is at least 1.5 mm smaller than the connection cable outer diameter

- Mounting method

Put the auxiliary cable armour on the tip of the cable armour as shown on the right. Then, wind the cable insertion part with self-fusing tape, and wind protective adhesion tape over it.

- Since the auxiliary cable armour is an optional component, it should be additionally ordered.

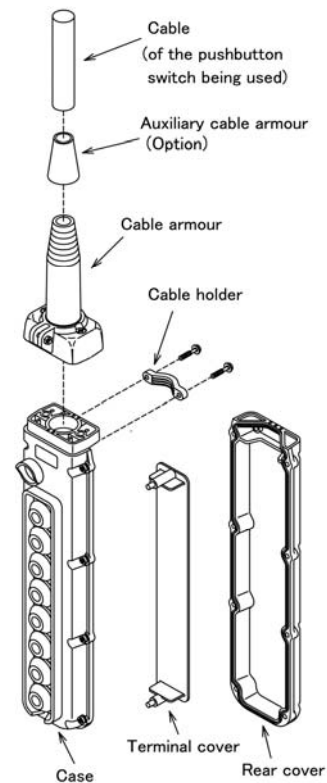

* Use it within the following range for the interference of an outside diameter of cable and an inside diameter of auxiliary cable armour

$$1 \text{ mm} \leq \text{Interference} \leq \text{half of an outside diameter of cable}$$

* Cut off the tip of the auxiliary cable armour by using scissors with a single action.

The auxiliary cable armour is made of silicone. When cutting the auxiliary cable armour, be careful not to cut it beyond the intended position.

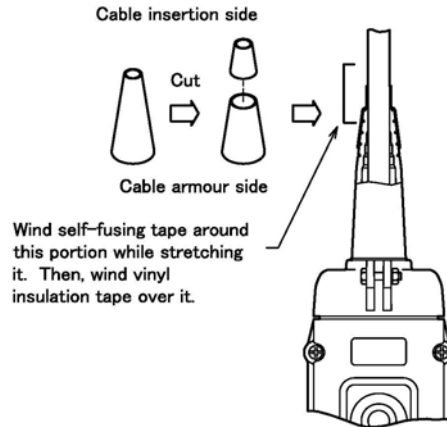

* Examples of products

Self-fusing tape: SUMITAPE B
(Sumitomo Electric Industries, Ltd.)
Protective adhesion tape: SUMITAPE C
(Sumitomo Electric Industries, Ltd.)



3-3 Button hood

- The button hood is a rubber cap that waterproofs the pushbutton holes in the case.

 [DANGER]	<p>- If the button hood has a cut or crack, replace it. * Otherwise, water or dust may enter the hood, which will result in a switch failure, or causes the crane/hoist to run out of control.</p>	
	<p>- Do not use the one other than model WC-L on the three speed switch unit. *There is a possibility that the switch is turned on when other caps are used.</p>	

Types of button hood

Model	Color	Remarks	Type	Color	Remarks
WC-B	Black	Standard accessory	WC-BH	Black	Holding type (SBIU-H3)
WC-R	Red		WC-RH	Red	
WC-G	Green		WC-BS	Black	Cold-resistant
WC-Y	Yellow		WC-RS	Red	
WC-L	Blue	SBIU-T standard	WC-BF	Black	Heat & chemical resistance
WC-LB	Black	SBIU-T	WC-M	Black	Rubber bushing
WC-LY	Yellow				

* The WC-BH/RH button hood is dedicated to the SBIU-H3 holding-type unit. The switch ON/OFF status can be visually checked.

* If the ambient temperature may fall below -10°C, be sure to use the silicone button hood (WC-BS). (Recommended temperature: 0°C or less)

3-4 Blank plug

WPI-O	Orange	Blank plug (Standard accessory)
-------	--------	---------------------------------

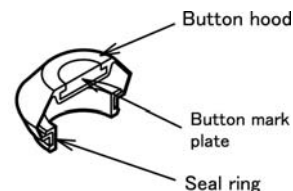
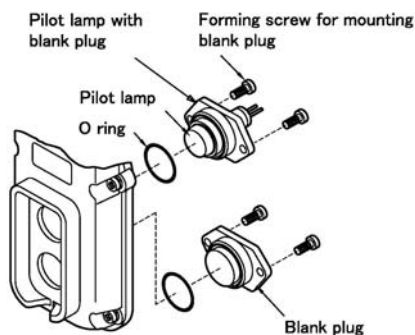

* Unless otherwise specified, the blank plug (WPI-O) is provided as the standard accessory, instead of the rubber bushing (WC-M).

* When the pilot lamp with the blank plug is used, the pilot lamp can be mounted at any position.

3-5 Top cover

- The equipment can be identified by replacing different color of top cover where two or more cranes/hoists are used.
- There are four kinds of colors of the top cover (red, blue and green) in total besides orange as standard color.
- When ordering, inform the necessary colors (red, blue and green) to provided with top cover.
- The top cover unit is not available for supply.

3-6 Protector (Option)

- The protector is a component for preventing the pushbutton switch from damage.
- Since the protector is an optional component, it should be additionally ordered.
- Material: Hard rubber

Type	Applicable pushbutton switch
CRI-1	SBI-2, 3, 4, 5, 6-W
CRI-2	SBI-7, 8, 10-W
CRI-3	SBI-12-W

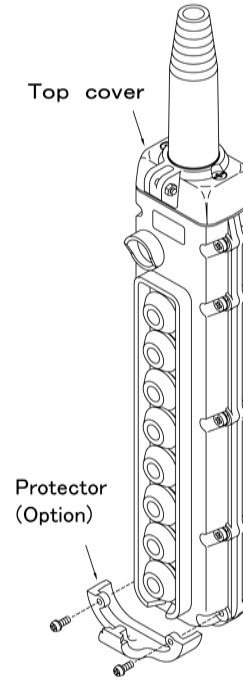





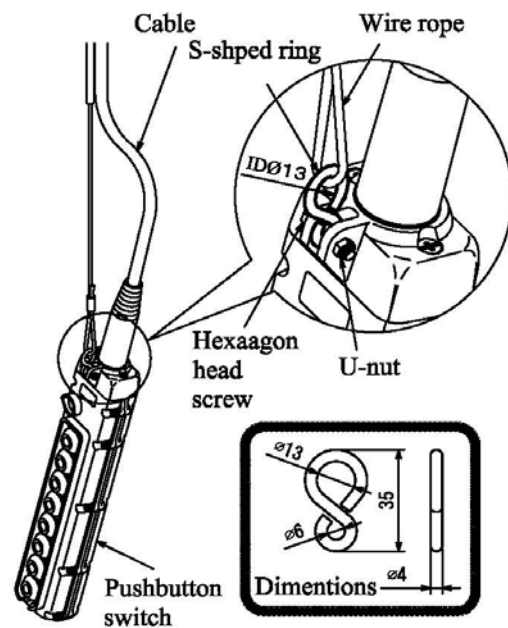



3-7 S-shaped ring as Hanger bracket (Option)

- For hanging pushbutton switch with a wire rope, etc. of 4 mm or more in the outside diameter, the S-shaped ring is available.
- The material of the S-shaped ring is stainless steel.
- The wire rope, etc. up to 12 mm can be put through the S-shaped ring.
- Since the S-shaped ring is an optional component, it should be additionally ordered.



[4] Wring, assembly and installation of the pushbutton switch

 [DANGER]	
<ul style="list-style-type: none">- Any person other than qualified personnel or those with expertise must not conduct the electric wiring.	
<ul style="list-style-type: none">- Select the cable armour whose tip inner diameter is smaller than the outer diameter of the cable being used.<ul style="list-style-type: none">* If the armour tip inner diameter is larger than the cable outer diameter, water or dust may enter the case. This will result in a switch failure, or causes the crane/hoist to run out of control.	
<ul style="list-style-type: none">- Do not use the SBI series pushbutton switch in a place where it may be in contact with, or exposed to an organic solvent.<ul style="list-style-type: none">* The pushbutton switch will develop cracks, depending on the type, concentration and temperature of the solvent. In this case, water or dust may enter the case, resulting in a switch failure or causing the crane/hoist to run out of control.	
<ul style="list-style-type: none">- Install the pushbutton switch so that it is kept suspended.<ul style="list-style-type: none">* Determine the cable length so that pushbutton switch cannot be placed on a level plane (such as table top or floor surface).* Otherwise, the pushbutton switch may be immersed in water (such as puddle), causing the crane/hoist to run out of control.	

 [CAUTION]	
<ul style="list-style-type: none">- When the case is opened, avoid placing the pushbutton switch in a place with much dust or sand.<ul style="list-style-type: none">* If a foreign object enters the case, malfunction or trouble may occur.- For terminal connections, use round crimp terminals. Do not solder the wires, or do not connect the bare wires directly.<ul style="list-style-type: none">* Otherwise, a trouble may occur.- After wiring of the cabtyre cable, do not use a cable that contains talc powder that may accumulate in the pushbutton switch, or a cloth inside the sheath.<ul style="list-style-type: none">* Otherwise, switch malfunction may occur.- Do not use a cabtyre cable that has a cut or crack in the sheath.<ul style="list-style-type: none">* Otherwise, water may enter the cable, resulting in a switch failure, or causing the crane/hoist to run out of control.- During assembly, be sure to mount the terminal cover to ensure safety.	
<ul style="list-style-type: none">- To prevent direct tension from being applied to the cabtyre cable, suspend the pushbutton switch with wires.<ul style="list-style-type: none">* Otherwise, the cable may break.	

[NOTE]

- To use the pushbutton switch in a place where an organic solvent is present, consult SHINKO or authorized distributor.
- To use the pushbutton switch in a place where it is exposed to high-temperature heat radiation (for example, in a metal casting plant), consult SHINKOH.
- To conduct electric wiring properly, commission a qualified electrician with understanding of this instruction manual.
- The electric wiring shall be conducted in accordance with electrical equipment technical standards and indoor wiring regulations.

4-1 Wiring and assembly procedures

* For screw tightening torque of relevant parts, refer to page 4.

- Tools prepared by user

(1) Prepare a Philips screwdriver (JIS No. 2), cutting knife, and crimp tool.

- Disassembling the case

(1) Loosen two screws (M5) that fasten the top cover, and remove the top cover.

* You can conduct the wiring work more efficiently by removing the top cover.

(2) Loosen the screws (M4) in the case, and remove the rear cover.

(3) Loosen two screws (M4) that hold the cable, and remove the cable holder.

(4) Remove the terminal cover.

- Wiring

(1) Pass the cable into cable armour mounted to the top cover by the case length.

* Use a vibration proof cabtyre cable.

* When using the auxiliary cable armour, pass the cable into the auxiliary cable armour first.

(2) Unsheathe the cable until the cable holder.

* Do not damage an insulation of cord.

(3) Mount the top cover to the case. For tightening torque, refer to page 4.

(4) Hold the cable with the cable holder.

(Tighten up a screw by the torque from which the cable does not come off at a force of 88N (9kgf))

(5) Cut the wires according to each terminal position, and attach crimp terminals.

* Use the round crimp terminals of Type V1.25-4 or equivalent type.

(6) Press the wires against the case inner surface.

* Connect the wire to the terminal at the longest distance from the cable holder position first.

(7) Check if the wiring between the pushbutton switch and control panel is correct.

(8) Check if the wires are not short-circuited.

- Assembling the case

(1) Clean inside of the case. (Check if there is no cable waste inside.)

(2) Mount the terminal cover.

(3) Make sure that the string packing is fit in the groove of the case.

(4) Make sure that the cable is not protruding from the case.

(5) Set the rear cover on the case, and tighten the screws.

(6) This completes the case assembly procedure.

4-2 Assembly precautions

- If the SBI series pushbutton switches is in contact with, or exposed to a solvent, it may develop cracks depending on the type, concentration and temperature of the solvent.

Before using the pushbutton switch, check if it is resistant to the solvent.

- To prevent direct tension from being applied to the cabtyre cable, suspend the pushbutton switch with wires. Determine the cable length so that pushbutton switch cannot be placed on a level plane (such as table top or floor surface).

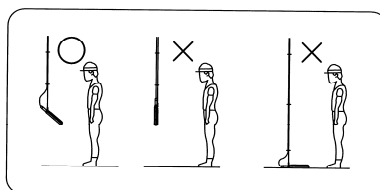

[5] Precautions for crane/hoist operations

[DANGER]

- Any person who does not have a thorough understanding of this manual must not operate the pushbutton switch.
The qualification is needed according to the usage. 
- If a cut or crack is found in the case, button hood, cable armour or cabtyre cable, do not perform crane/hoist operations with the switch under the defective condition.
- Do not allow the pushbutton switch to be immersed in water (e.g. puddle).
 - * If water enters the case, it will result in a switch failure, or causes the crane/hoist to run out of control.

- Be sure to conduct preoperational inspection and voluntary periodic inspections.
 - * Operating the equipment in abnormal conditions causes the crane/hoist to run out of control, or an accident such as electric shock. 
- Before using the pushbutton switch, be sure to check if it smoothly operates.
 - * If the pushbutton switch malfunctions or abnormally operates, the operator may suffer from injury.

- If the crane/hoist moves in a different direction regardless of the control via the pushbutton switch, stop operation immediately. 
- * If the pushbutton switch malfunctions or abnormally operates, the operator may suffer from injury.

[CAUTION]

- When the cabtyre cable is obliquely pulled, do not release the pushbutton switch from your hand.
 - * If the pushbutton switch is abruptly released, it may hit against people, resulting in injury, or malfunction or damage to equipment. 

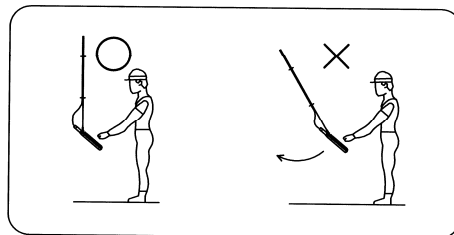

- Push each pushbutton all the way to the innermost.
 - * If the pushbutton is not completely pushed in, the switch may malfunction, causing injury.
- Clean the area around the pushbutton switch to keep it free from dust or sand.
 - * Otherwise, the pushbutton switch may malfunction.

5-1 Precautions for operation and control

- Do not place the pushbutton switch on a level plane (such as table top or floor surface).
- During operation and control, keep watching the surroundings to ensure safety.
- During operation, check if the crane moves in the direction specified by the pushbutton switch.
- During operation, the operator should face the load, and advance forward.
- In principle, do not operate two or more pushbuttons simultaneously.
- Avoid operating the pushbutton switch while holding the load or wire rope with one hand.
- After operation is completed, keep the pushbutton switch in place.

It is recommended that the equipment for outdoor use should be provided with a rain cover.

- If a power failure occurs during operation, turn off the power switch.
- If you intend to leave the equipment unused for a long period, or to temporarily stop operation, turn off the power switch.

5-2 Emergency procedure

- If you are concerned about any point during operation, report it to the person in charge.
- If you find abnormality with the crane/hoist in operation, stop the operation immediately, and ask the person in charge to give instructions.

[6] Inspection standards



- **Before using the equipment, be sure to conduct preoperational inspection.**
- **If you find abnormality with the equipment, stop operation immediately, and replace the defective part.**
 - * **Do not operate the equipment under abnormal conditions. It is dangerous and causes an accident.**
- **To use the pushbutton switch safely, be sure to conduct voluntary periodic inspections.**
 - * **Conduct monthly voluntary inspection at least once a month, and yearly voluntary inspection at least once a year.**
- **Voluntary periodic inspections must be conducted by authorized personnel with expertise.**
 - * **Abnormal operation results in an accident.**



- **If abnormality is found in monthly or yearly voluntary inspection or other inspection, never use the equipment under abnormal conditions.**
 - * **Do not operate the equipment under abnormal conditions. It is dangerous and causes an accident. Be sure to replace the defective part, and take an appropriate action.**



- The inspections should be conducted in accordance with relevant laws and regulations, and also referring to “Guideline for Voluntary Periodic Inspections on Overhead Traveling Cranes” (notified by the Ministry of Health, Labor and Welfare on March 31, 1998).
- Relevant laws and regulations: Labor, Safety & Health Law, Enforcement regulations for the Labor, Safety & Health Law, Labor and Safety Regulations, Safety Regulations for Cranes and Structure standard of crane etc.

6-1 Preoperational inspection

- Visually check the following points:

Inspection item	Inspection standards
Appearance	<ul style="list-style-type: none"> - The case has no break or crack. - The screws are securely tightened. - The button hood has no cut or crack. - The connection cable has no cut or crack. - The wire for suspending the pushbutton switch is effective.
Switch operations	<ul style="list-style-type: none"> - Each pushbutton smoothly operates according to the indication (UP, DOWN, LEFT, RIGHT). When the pushbutton is released, operation immediately stops. - The interlock normally works.

6-2 Voluntary periodic inspections

(1) The inspection items shall be absolutely required items. The inspection interval is as follows:

Class A: Inspection items important in terms of safety.

These items must be inspected at least once a month.

Class B: Inspection items important for maintenance. (Frequently used parts)

These items must be inspected every three months.



Class C: Inspection items equivalent to Class B, and consumable parts.

These items must be inspected every three months.

(2) Be sure to keep the inspection records (for at least three years).

Inspection item	Category	OK/NG	Description/Action	Date
- Check each terminal and tightening screw for looseness.	A			
- Check the pushbutton operating conditions. Check if the interlock is complete.	A			
- Check the cable armour for damage	A			
- Check the case and button hood for damage.	A			
- Check the insulator for damage.	B			
- Check each contact for wear.	C			

[7] Maintenance

 [DANGER]	
<p>- Before removing the rear cover from the pushbutton switch, turn OFF the power switch. * Otherwise, you may get an electric shock.</p>	
<p>- Do not use the one other than model WC-L on the three speed switch unit. *There is a possibility that the switch is turned on when other caps are used.</p>	

 [CAUTION]

- Before closing the rear cover, shake the case, or blow air to remove dust or waste from inside of the case. Using vacuum is also effective.
- * A foreign object remaining in the case causes malfunction or trouble.
- When removing the seal ring, it may break into pieces. Remove chips of the seal ring completely from the case.
- * A foreign object remaining in the case causes malfunction or trouble.
- The seal ring must not be reused.
- * Used seal ring does not provide sufficient sealing effect, causing a trouble.



- Before parts replacement, be sure to read the following instructions carefully for thorough understanding. If any part other than those listed here is defective, you must replace the whole unit of the pushbutton switch.

7-1 Replacement of the switch unit

- Remove the switch unit from the resin case, and remove the resin chips adhering to the unit mounting holes and screws. Residual resin waste may cause malfunction.
- For case disassembly procedure, refer to “4-1” on page 10.
- For case assembly procedure, refer to “4-1” on page 10.
- For tightening torque, refer to page 4.
- Replacement procedure
 - (1) Remove the rear cover.
 - (2) Remove the terminal cover.
 - (3) After recording the wire connections of the switch unit to be replaced, remove the terminals.
 - (4) Loosen the switch unit mounting screws to remove and replace the unit.
 - (5) Connect wires to individual terminals as recorded.
 - (6) Mount the terminal cover.
 - (7) Mount the rear cover.

7-2 Replacement of the button hood

- Standard replacement method
 - (1) Remove the rear cover.
 - (2) Remove the terminal cover.
 - (3) After recording the wire connections for the switch unit to be replaced, remove the terminals. Then, remove the switch unit.
 - (4) To remove the button hood, tap a resin hammer or end of a screwdriver handle on the seal ring (white) from the inside of the case.
 - (5) Press-fit a new button hood into the case by using both thumbs from the operation panel side.
 - (6) Connect wires to individual terminals as recorded.
 - (7) Mount the terminal cover.
 - (8) Mount the rear cover.

- Simplified replacement method

- (1) Remove the button hood to be replaced by pulling it out with long-nose pliers from the operation panel side.
- (2) Remove the remaining seal ring (white) by prying it away with a flat blade screwdriver.
- (3) Press-fit a new button hood into the case by using both thumbs from the operation panel side.

- Replacement of the button mark plate

- (1) Remove the button mark plate by inserting a small flat blade screwdriver into the groove at the top of the button hood, and mount a new one.

* During replacement of the button mark plate, be careful not to damage the button hood.

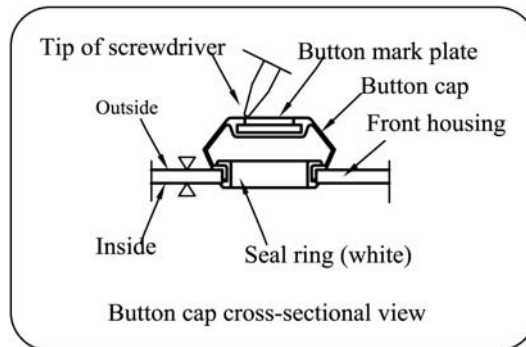

7-3 Replacement of the pilot lamp, buzzer switch and control switch

- Replacement of the pilot lamp

- (1) Remove the rear cover.
- (2) Remove the cable and the nut.
- (3) To remove the pilot lamp, push it out with your finger from inside of the case.
- (4) Press-fit a new pilot lamp (with O ring) into the mounting hole from outside of the case.
- (5) Tighten up the nut of pilot lamp. Push the fastening terminal into the receptacle.
- (6) Close the rear cover.

* For the fastening terminal, use a fastening receptacle equivalent to TMEDN 480520-FA (NICHIFU).

* When connecting the cable, do not pull the cable with the fastening terminal strongly, or bend it repeatedly. Such actions cause cable breaks.

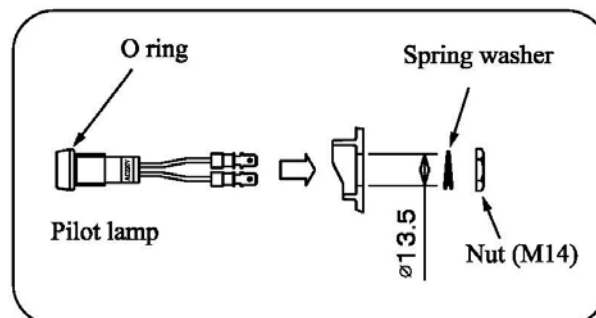

- Replacement of the buzzer switch

- (1) Remove the rear cover.
- (2) Remove the cable, and remove the M14 nut and spring washer.
- (3) To remove the buzzer switch, push it from inside of the case.
- (4) Press-fit a new buzzer switch into the mounting hole from outside of the case.
Remove the terminal screws before inserting the buzzer switch.
- (5) Align the upper and lower edges of the indication, and mount the spring washer and nut.
- (6) After connecting the cable, close the rear cover.

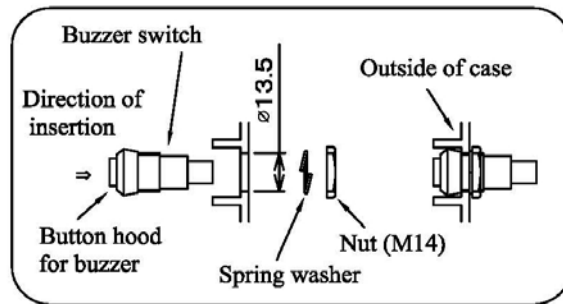

- Replacement of the control switch model SBU-H1

- (1) Remove the rear housing.
- (2) Remove wiring, and turn the fixed contactor base counterclockwise by 45° while attracting an external cover in the fixed contact base's direction.
- (3) Pull the fixed contactor base from push button, and remove the nut.
- (4) The casing, anti-rotation washer and the ring come off when pushing it out of the inside of the front housing with the finger.
- (5) Push the casing from the outside of the front housing into the hole.
Confirm the packing is assembled to the casing.
- (6) The casing that a round sign turns to the vertical direction is inserted in the front housing. And, anti-rotation washer and the ring are assembled.
- (7) Tighten the nut.
The tightening torque is 15 kgf.cm (147Nm).
- (8) Incline the fixed contactor base by 45° and insert it in the casing.
- (9) Rotate the fixed contactor base by 45°.
- (10) Shut the rear housing after it wires.

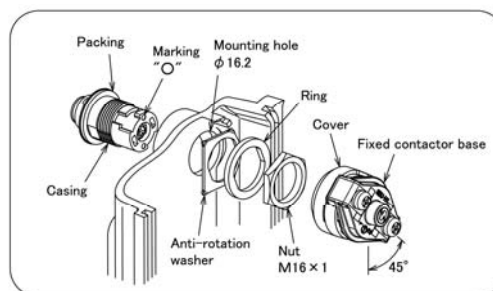

[8] Warranty

8-1 Scope and period of warranty

This warranty document prescribes the scope of warranty on the pushbutton switch.

(1) Scope of warranty

If a failure or defect is found with any of the genuine components of the pushbutton switch within the warranty period prescribed below and it is attributable to an inadequacy in material or manufacturing process, SHINKOH shall replace the defective component, or the whole unit.

(2) Items subjected to warranty, and period of warranty

The items subjected to warranty, and the period of warranty are as follows:

- Items subjected to warranty

1) All components and accessories that have been mounted before shipment.

However, any item corresponding to the “exemptions from warranty” prescribed below shall be excluded from the scope of warranty.

2) Products used in Japan

(For products used overseas, contact SHINKOH.)

- Period of warranty

The warranty period is one year from the date of delivery.

8-2 Exemptions from warranty

(1) Failure or defect judged to be attributable to the following factors:

- Use under conditions exceeding the specified limits
- Inadequacy or error in installation (including wiring), maintenance and inspection
- Modification or use unauthorized by relevant laws/regulations or the manufacturer

(2) Failure or defect listed below:

- Failure or defect attributable to external factors, such as soot, chemicals, heat radiation or dust.
- Sensory phenomenon having no functional influence
- Wear from use, and secular change (e.g. damage to button hood)

(3) SHINKOH shall not bear the following expenses, even within the period of warranty.

- Damage of being caused due to breakdown of products.
- Expenses for inspection, adjustment and cleaning
- Expenses for replacement, and incidental expenses
- Compensation for the loss resulting from the disabled pushbutton switch
(Secondary loss, such as communication expense and discontinuation of business operations due to the failure)

(4) Other exemptions

- SHINKOH products have been designed and manufactured as general-purpose industrial equipment.

When the products are used in the fields that may have significant influence on people's lives and properties, such as nuclear power generation, aviation, railroad, medical equipment and so on, they are beyond the scope of warranty.

- To ensure accurate judgment and quick response, be sure to inform us of the serial number of your equipment when you contact us for inquiry.

The serial number is stamped on the inside of the rear cover.

- For future reference, fill in the following items:

1) Model

2) Serial number

3) Date of purchase

BUSINESS LINES

for control of crane and hoist

PUSH BUTTON STATION

for safety of control circuit

"ELE-CUT" relay

for power distribution

"SDM" rail system

for suspension of electric/pneumatic supply

CABLE/HOSE HANGERS

for power trolley

POWER COLLECTORS

for power supply and insulation

WIRING MATERIALS



1-5-16 YAMASAKA HIGASHISUMIYOSHI-KU
OSAKA-SHI OSAKA 546-0035 JAPAN
Phone +81-6-6629-1123 Facsimile +81-6-6623-1133
URL <http://www.shinkoh-electric.co.jp/>
E-mail sales@shinkoh-electric.co.jp



* The performance and specifications are subject to change without prior notice as improvements are made in the product.